



Figure 1. The Physical Photo of ATHS-1/2/105/66/30A

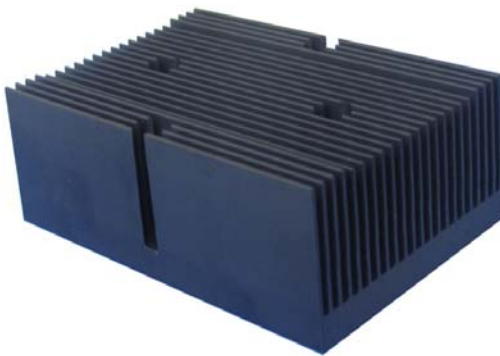

Figure 2. The Physical Photo of ATHS-1/2/105/66/30H4

FEATURES

- Material: Aluminum
- Surface: Black Anodized Processing
- Unidirectional Pin Fin
- Excellent Conductivity
- Corrosion Resistance
- Available in Various Lengths
- Available with Pressure Sensitive Adhesives for Quick and Easy Mounting

DESCRIPTION

This heat sink is made up of aluminum and the surface is black anodized, both of which make an excellent heat dissipation rate and insulating property, resulting in a better effect in heat dissipation.

There are two types of heat sinks, ATHS-1/2/105/66/30A and ATHS-1/2/105/66/30H4. The former is without any holes, and the latter has four holes, as shown in Figure 1 and Figure 2.

The heat sink's thermal resistance is the most important parameter to choose heat sink.

Once the maximum safe junction temperature for the equipment (T_{jmax}) is known, the power is going to dissipate (P_d) and the maximum ambient temperature will work at (T_{amb}), thus the maximum total $R_{th(j-a)}$ from this expression:

$$R_{th(j-a)} = (T_{jmax} - T_{amb})/P_d$$

From the manufacturer's data, useful information, such as $R_{th(j-c)}$ can be found, the junction-case thermal resistance of the power equipment itself. Then add the thermal resistance of the thermal compound and/or insulating washer, and this will provide the total junction to sink resistance. Subtract this from the maximum $R_{th(j-a)}$ figure, and the maximum allowable heat sink resistance will be achieved. Then select a heat sink which will provide no more than this value of thermal resistance.

We can **CUSTOMIZE** a heat sink for you, with/without holes. The width of the heat sink is fixed, and the length can be customized.

APPLICATIONS

- Heat dissipation of the power equipment
- Heat dissipation of the graphics card
- Heat dissipation of CPU
- Heat dissipation of small and medium electrical appliance

SOLUTIONS

As everyone knows, all semiconductor devices have some electrical resistance. This means that when power diodes or power transistor is switching or otherwise controlling reasonable currents, they dissipate power as heat energy. High temperature makes the devices work unstably, thus shortens working life of the devices. If the device is not to be damaged by this, the heat must be removed from inside the device at a fast enough rate to prevent excessive temperature rise. The most common way to do this is by using a heat sink.

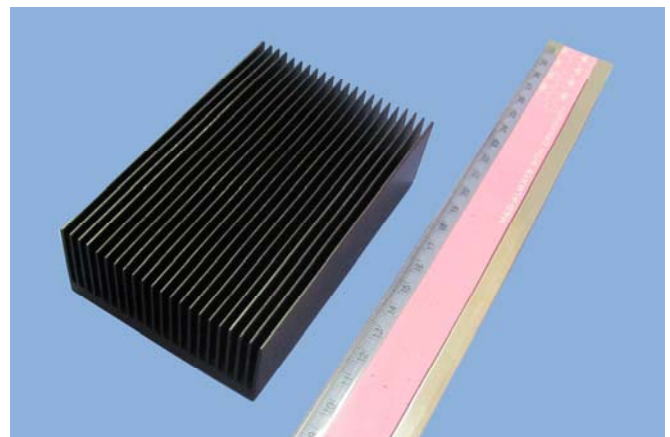

Figure 3. The Top View of ATHS-1/2/105/66/30A

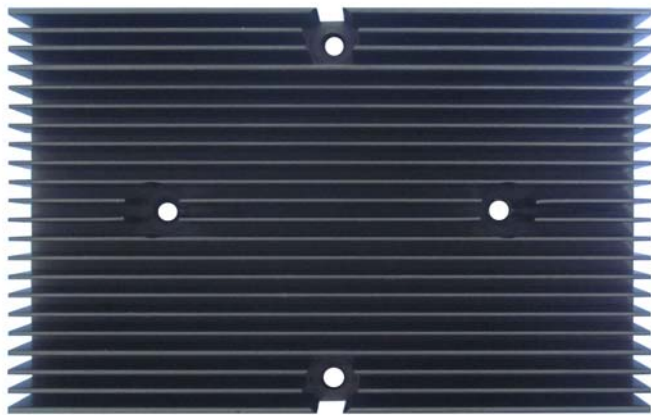

Figure 4. The Top View of ATHS-1/2/105/66/30H4

MATERIAL

The thermal conductivity of heat sink material is different. According to the thermal conductivity, the best material is silver, followed by copper, aluminum, and steel successively. Silver is too expensive, so we usually choose copper and aluminum alloy as heat sink material, either of which has its own advantages and disadvantages. Thermal conductivity of copper is good, almost twice as much as that of aluminum, but it's more expensive, weighty and easily being oxidized and has more difficulties in processing and smaller thermal capacity.

The most commonly used material is aluminum. Pure aluminum is not used in heat sinks, because it is too soft and cannot provide enough hardness. We usually use aluminum alloys. Thermal conductivity values depend on the temper of

the alloy. Compared with copper, aluminum is much cheaper and lighter. Another advantage is that it can be extruded, but copper cannot.

SURFACE COLOR

Radiative cooling may not be an important factor, but in some situations in which convection is very low, the surface color can be an important factor. Shiny bare metal cannot radiate as efficiently as matte black surface because of its low emissivity, while matte black has high emissivity, so it can radiate radiant efficiently.

ANODIZING

Anodizing is an electrolytic passivation process used to increase the thickness of the natural oxide layer on the surface of metal parts. Anodizing increases corrosion resistance and wear resistance, and provides better adhesion of paint primers and glues than bare metal does. Anodization changes the microscopic texture of the surface and changes the crystal structure of the metal near the surface.

For example, anodized aluminum surfaces are harder than aluminum but have low to moderate wear resistance that can be improved by increasing thickness or by applying suitable sealing substances. When pure aluminum is exposed to air at room temperature or any other gas containing oxygen, it can self-passivate by forming a surface layer of amorphous aluminum oxide 2 to 3 nm thick, which can protect aluminum from being corroded effectively. Compared with pure aluminum, aluminum alloys can form a thicker oxide layer, but it is also more easily being affected by corrosion. We can increase the anodized aluminum surface's thickness of this layer for corrosion resistance.

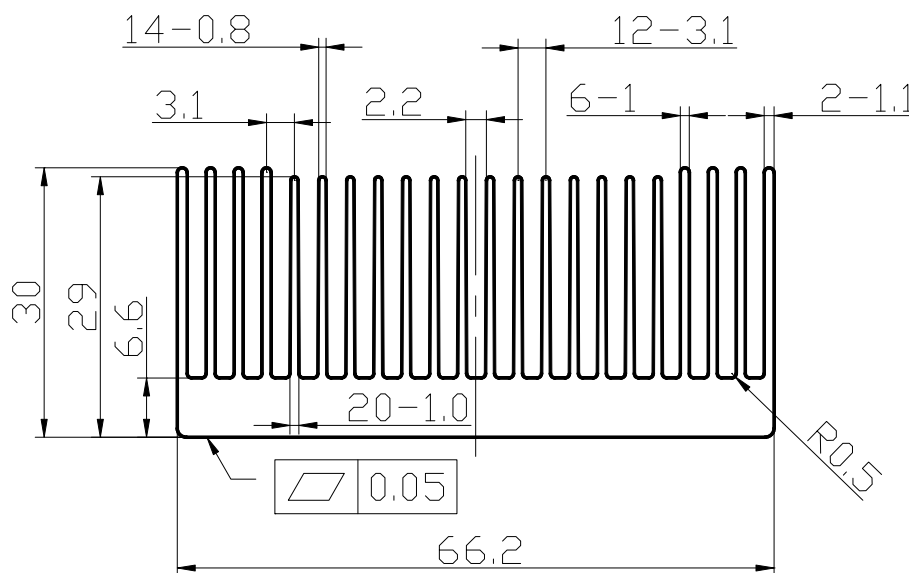

Figure 5. Mechanical Dimensions of Heat Sink ATHS-1/2/105/66/30A

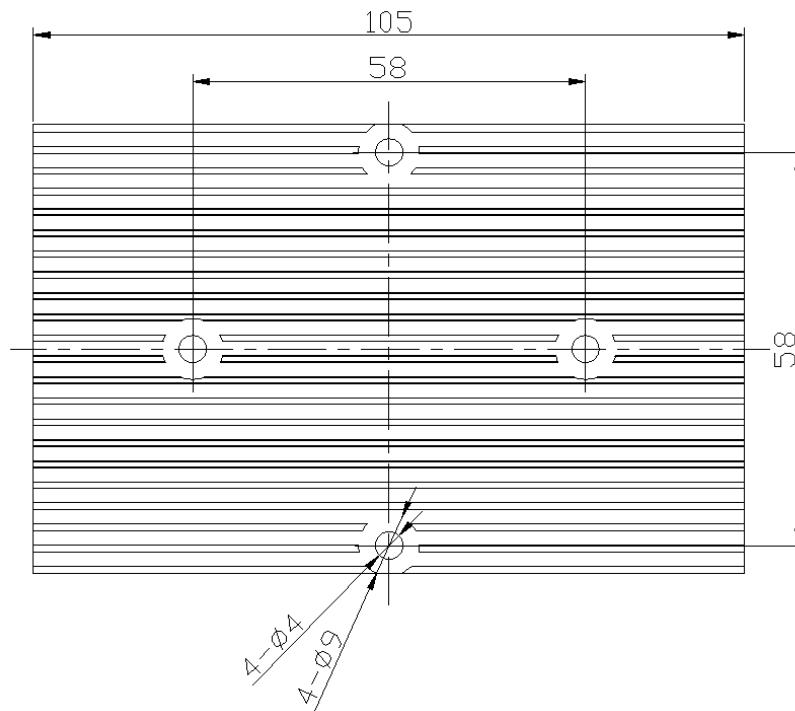

Figure 6. Mechanical Dimensions of Heat Sink ATHS-1/2/105/66/30H4

SPECIFICATIONS

Table 1 below shows the specifications of the heat sink.

Table 1. Characteristics

Part # / Specification	ATHS-1/2/105/66/30A	ATHS-1/2/105/66/30H4
Color	Black	Black
Material	Aluminum	Aluminum
Length	105mm	105mm
Width	66.2mm	66.2mm
Height	30mm	30mm
Weight	0.245 kg	0.245 kg
Hole Diameter	-	4mm
Hole Distance	-	58mm

Note: The width of the heat sink is fixed, but we can provide the heat sink with different lengths according to your requirement. Thermal resistance is measured in two conditions; one is with fans, and the other without fans, as shown in Table 2 below.



Table 2. Thermal resistance

Room Temperature	Fan		Thermal Resistance
29.9°C	No fans		2.35°C/W
29.9°C	With fans	Fan size	60×60×15mm
		Rotation speed	3500 RPM
		Flow rate	13.4 CFM
			0.3°C/W

ORDERING INFORMATION

Table 3. Unit price

Part #	1 - 4pcs	5 - 9pcs	10 - 49pcs	50 - 99pcs	≥ 100pcs
ATHS-1/2/105/66/30A	\$12	\$11.2	\$10.4	\$9.6	\$8.8
ATHS-1/2/105/66/30H4	\$12	\$11.2	\$10.4	\$9.6	\$8.8

NOTICE

- ATI warrants performance of its products for one year to the specifications applicable at the time of sale, except for those being damaged by excessive abuse. Products found not meeting the specifications within one year from the date of sale can be exchanged free of charge.
- ATI reserves the right to make changes to its products or to discontinue any product or service without notice, and advise customers to obtain the latest version of relevant information to verify, before placing orders, that information being relied on is current and complete.
- All products are sold subject to the terms and conditions of sale supplied at the time of order acknowledgment, including those pertaining to warranty, patent infringement, and limitation of liability. Testing and other quality control techniques are utilized to the extent ATI deems necessary to support this warranty. Specific testing of all parameters of each device is not necessarily performed, except those mandated by government requirements.
- Customers are responsible for their applications using ATI components. In order to minimize risks associated with the customers' applications, adequate design and operating safeguards must be provided by the customers to minimize inherent or procedural hazards. ATI assumes no liability for applications assistance or customer product design.
- ATI does not warrant or represent that any license, either express or implied, is granted under any patent right, copyright, mask work right, or other intellectual property right of ATI covering or relating to any combination, machine, or process in which such products or services might be or are used. ATI's publication of information regarding any third party's products or services does not constitute ATI's approval, warranty or endorsement thereof.
- IP (Intellectual Property) Ownership: ATI retains the ownership of full rights for special technologies and/or techniques embedded in its products, the designs for mechanics, optics, plus all modifications, improvements, and inventions made by ATI for its products and/or projects.